

**FRANK OTTERBACH
SALES MANAGER
DANIELI FRÖHLING**

**4TH IIAC IRAN INTERNATIONAL
ALUMINIUM CONFERENCE
OLYMPIC HOTEL
TEHRAN, IRAN
11-12 MAY 2016**

DANIELI FRÖHLING HIGH-SPEED SLITTING AND TRIMMING LINES TURNKEY FINISHING WORKSHOP SOLUTIONS

**DANIELI
PASSION TO INNOVATE
AND PERFORM
IN THE METALS INDUSTRY**



1. **TURNKEY FINISHING**
WORKSHOP
2. **HIGH-SPEED SLITTER**
3. **PIT SLITTER - TAB STOCK**
4. **PIT SLITTER - AUTOMOTIVE**
5. **PACKING LINE - AUTOMOTIVE**
6. **SUMMARY**

1. ENTRY COIL LOGISTICS
2. COIL PREPARATION
3. HIGH SPEED SLITTER
4. PIT SLITTER
5. BIG COIL PACK LINE
6. SLIT COIL PACK LINE

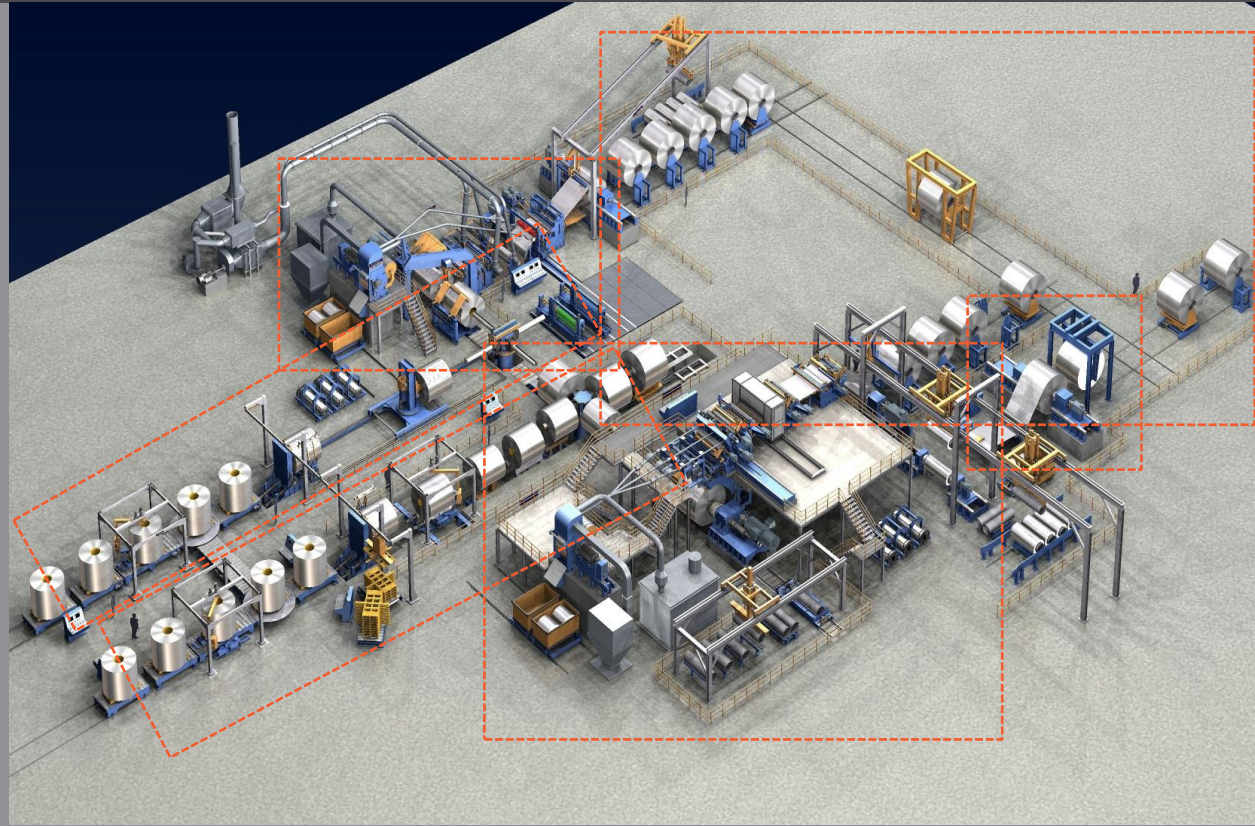

MAIN DATA

Line Speed: 1,800 m/min

Strip Width: max. 2600 mm

Strip Thickness: max. 1.00 mm

Number of finished strips: 2

Coil Weight: max. 34.000 kg

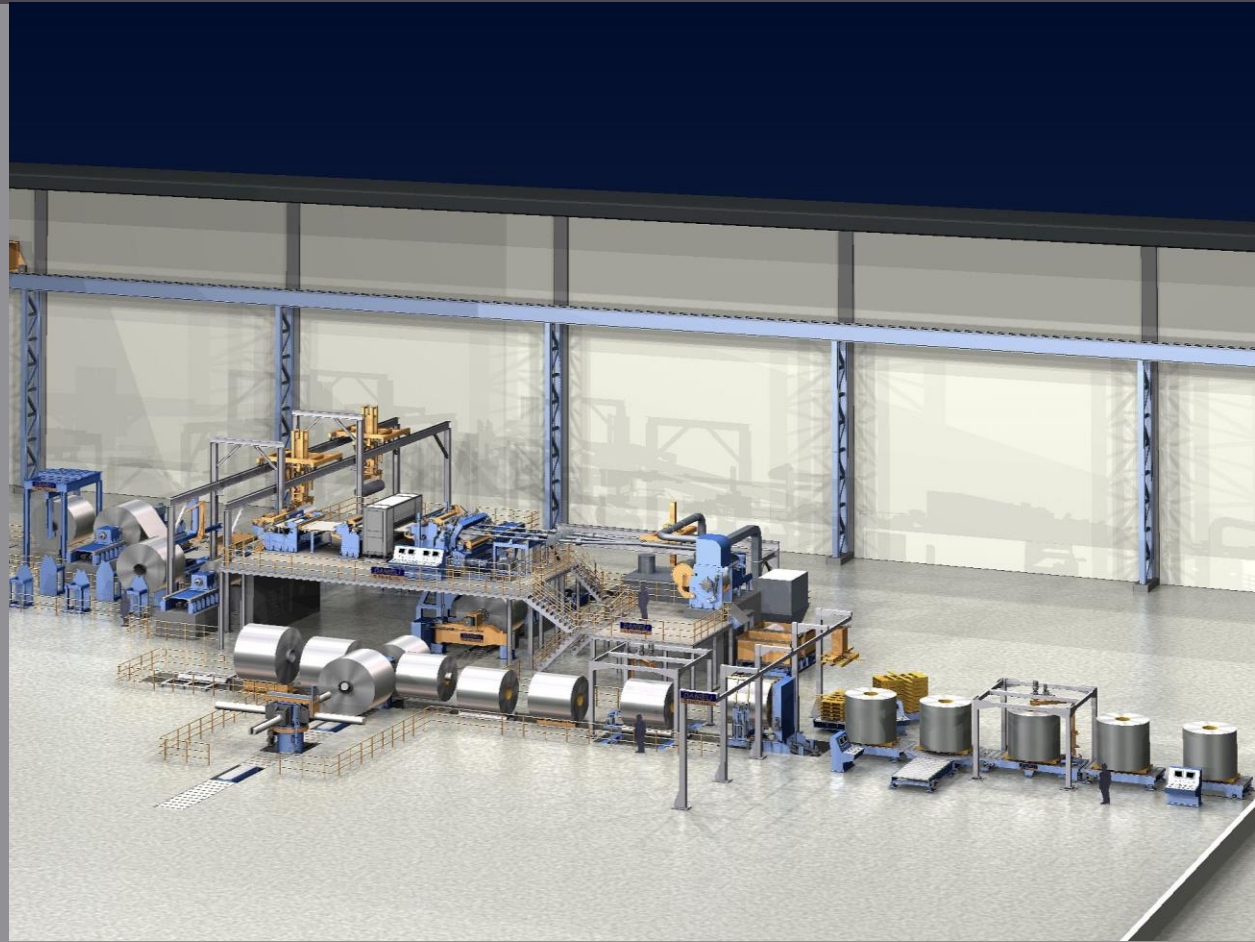

LINE FEATURES

- CNC Slitter head;
- Suction device for trimmed and center scrap;
- Vertical exit following and ironing roll;
- Automatic strip taping;
- Spool handling un-coupled from coil car;
- DF-Coulomb_{OPT} Electrostatic Oiler - Can Stock;

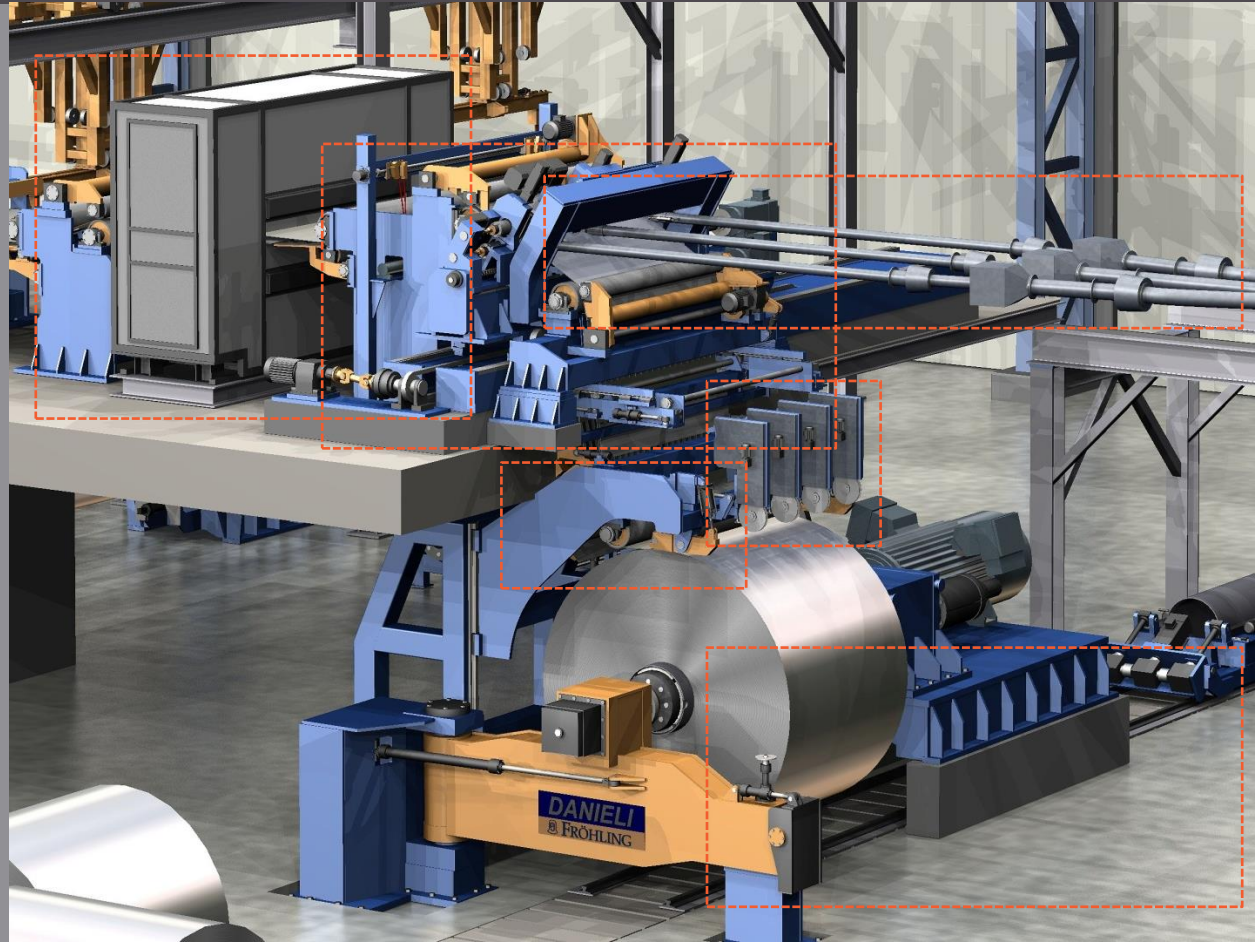

MAIN DATA

Line Speed: 800 m/min

Strip Width: max. 2400 mm

Strip Thickness: max. 0.08 mm

Number of finished strips: 130

Coil Weight: max. 34.000 kg

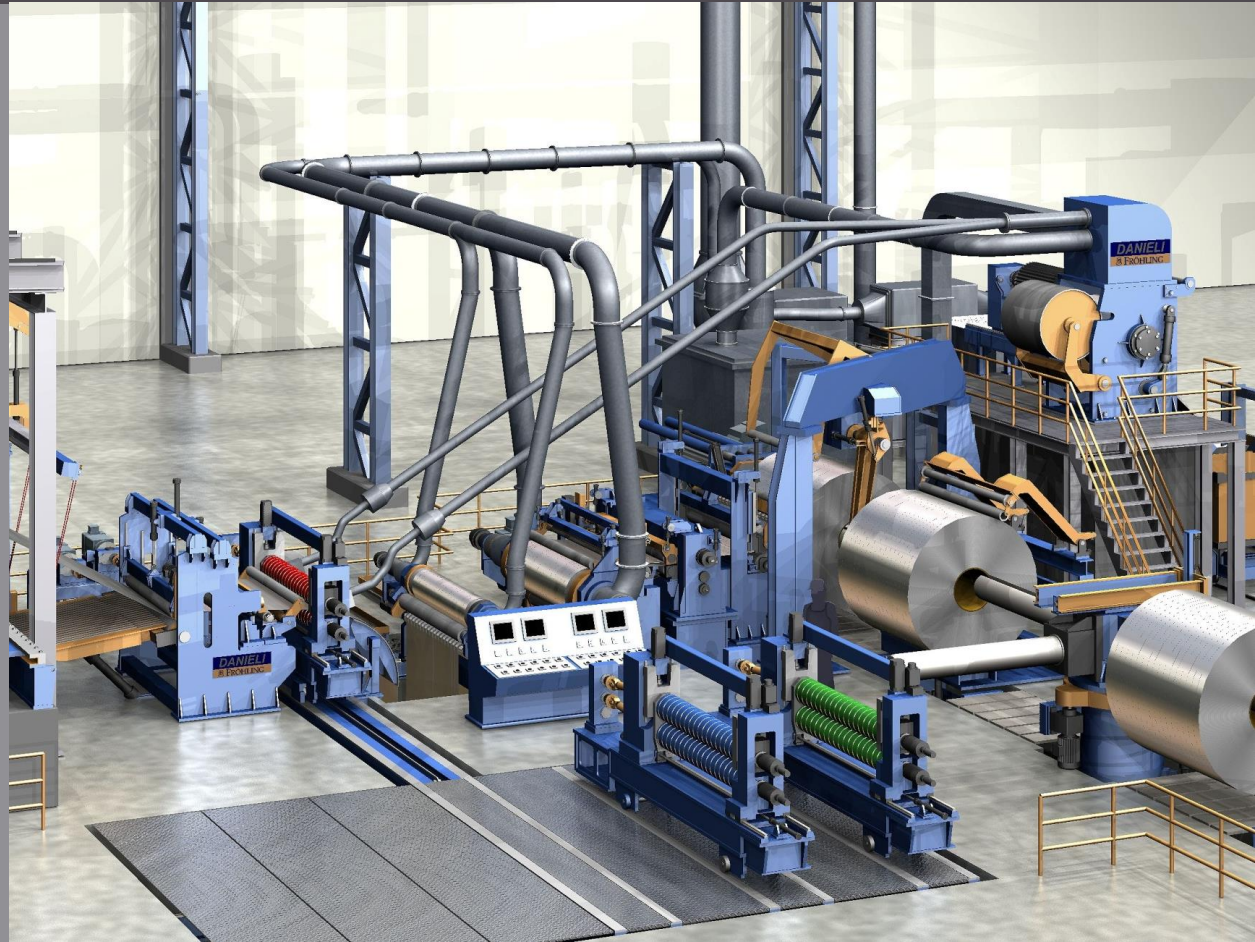

LINE FEATURES

- > CNC Slitter head;
- > Shear changing device for 2nd and 3rd off-line slitter;
- > DF Vacuum roll double loop
- > DF Vacuum brake roll;
- > Suction device for trimmed and center scrap;

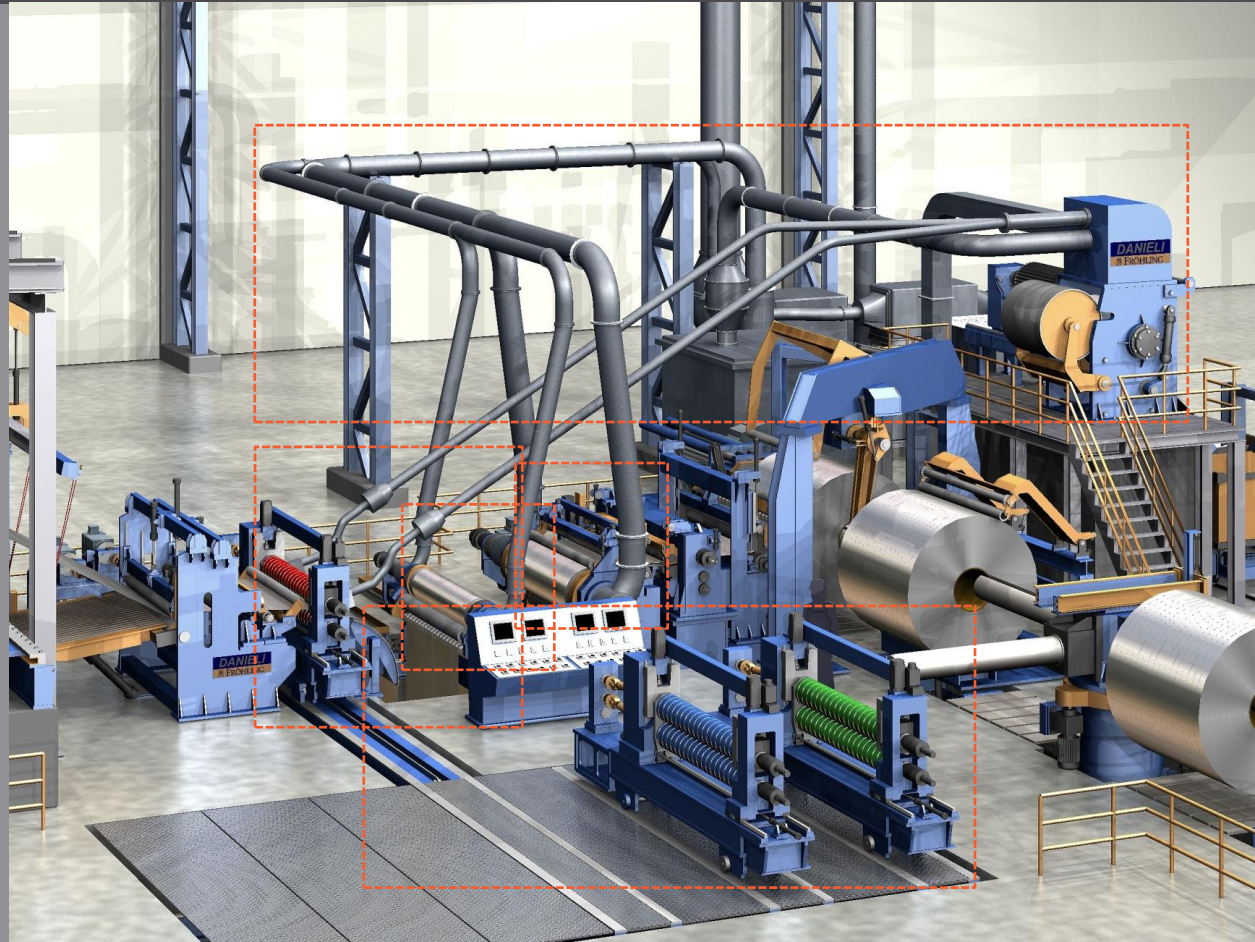

MAIN DATA

Line Speed: 600 m/min

Strip Width: max. 2450 mm

Strip Thickness: max. 3.50 mm

Number of finished strips: 30

Coil Weight: max. 34.000 kg

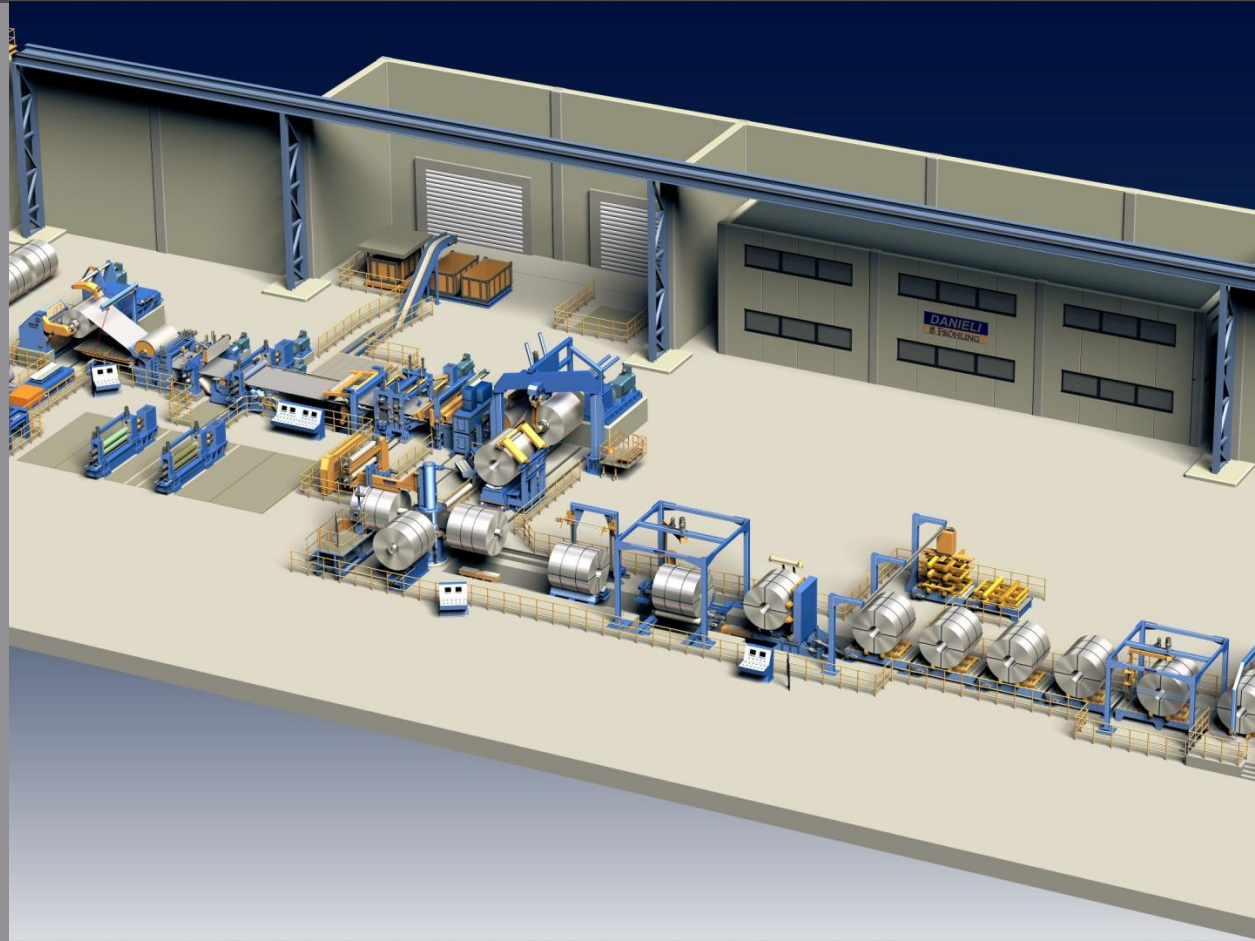

PIT SLITTER
AUTOMOTIVE

DANIELI FRÖHLING TURNKEY FINISHING WORKSHOP
CAN STOCK AND CAN END

DANIELI

PIT MODE !

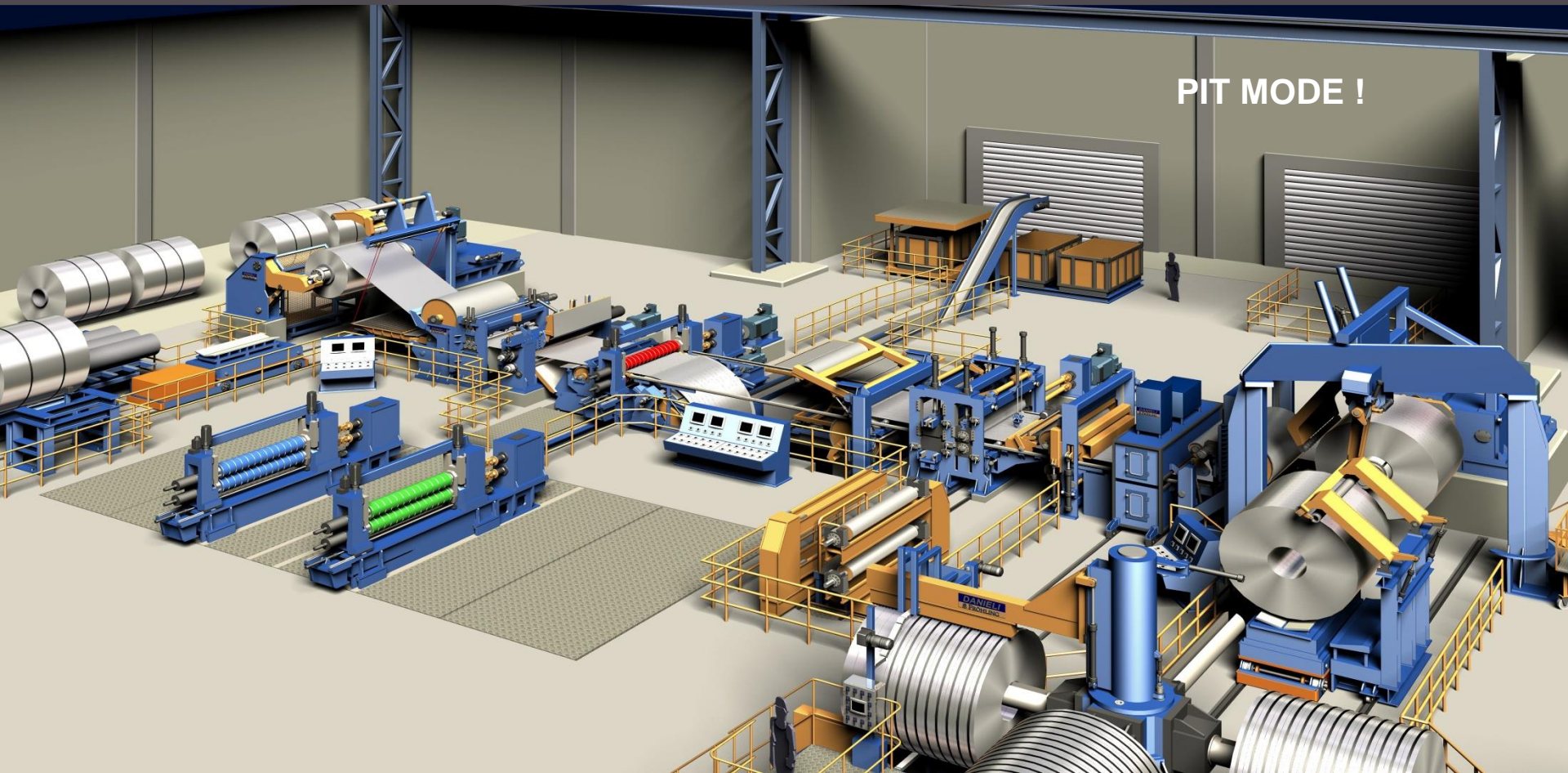

TIGHT MODE !

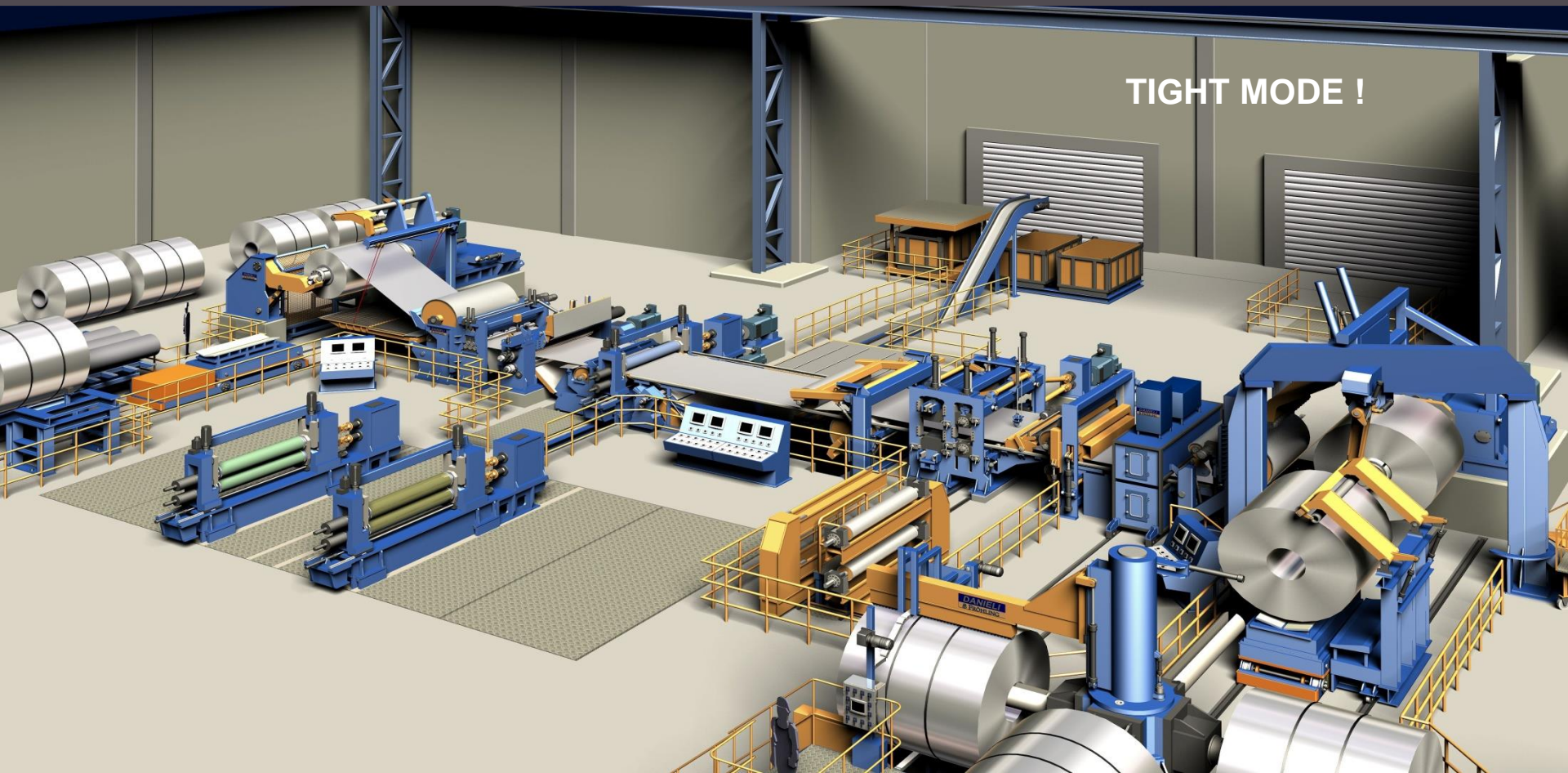

LINE FEATURES:

- CNC Slitter head
- Shear changing device for 2nd and 3rd off-line slitter
- Combined braking system work system changeable brake rolls
- DF-Coulomb_{OPT} Electrostatic Oiler - dry lube

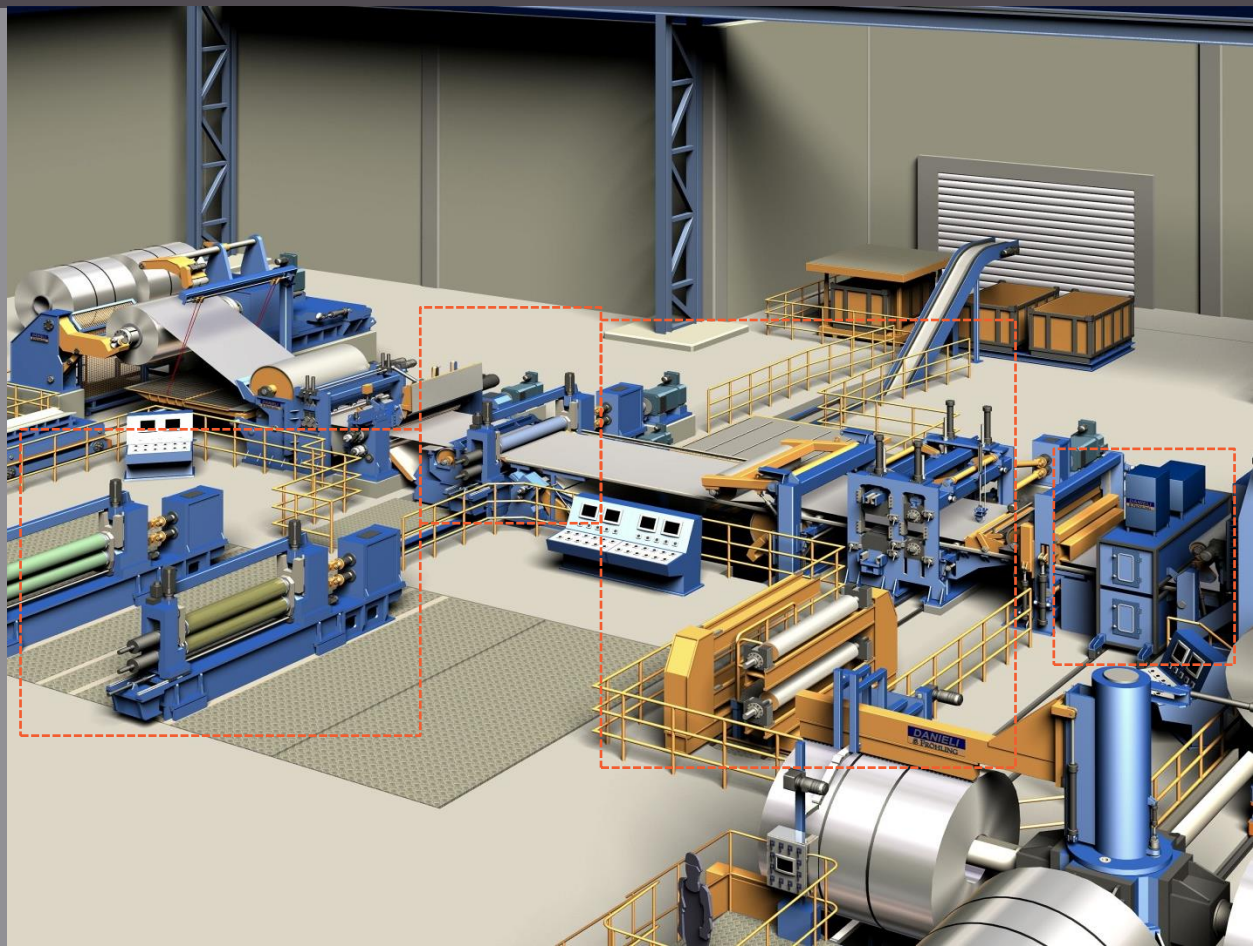

SLIT COIL
EYE TO SKY

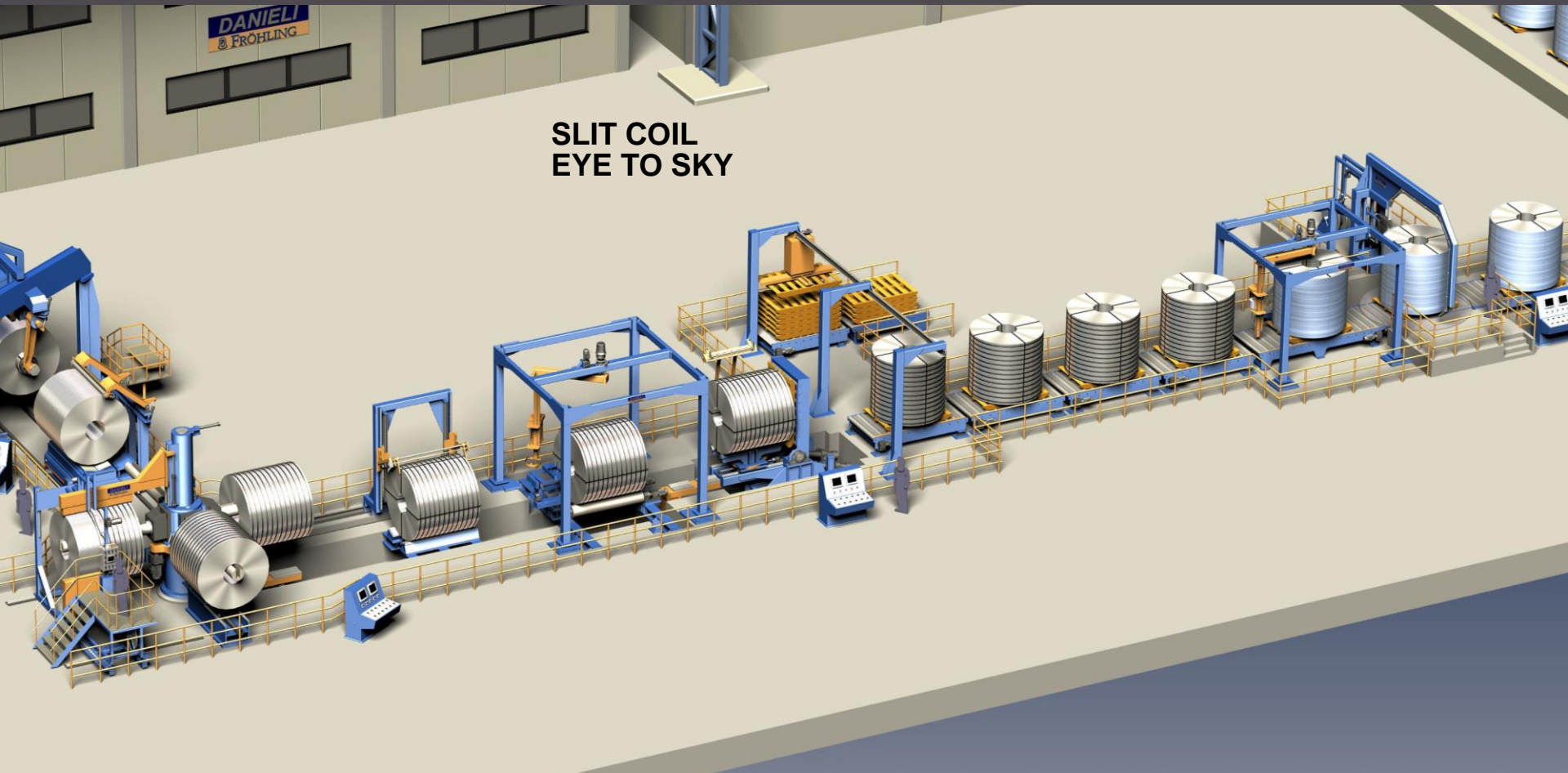

**TRIMMED COIL
EYE TO SIDE**

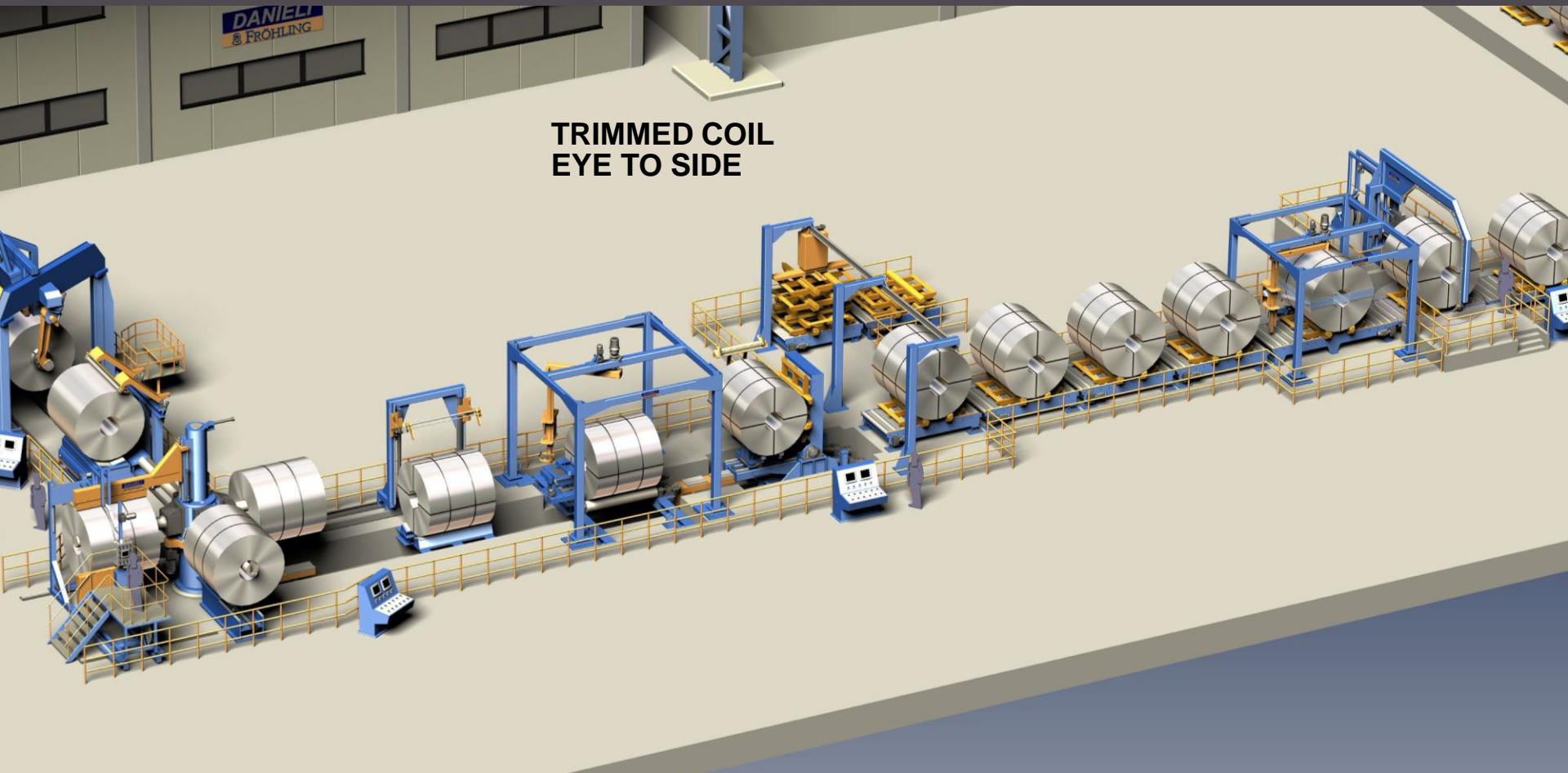

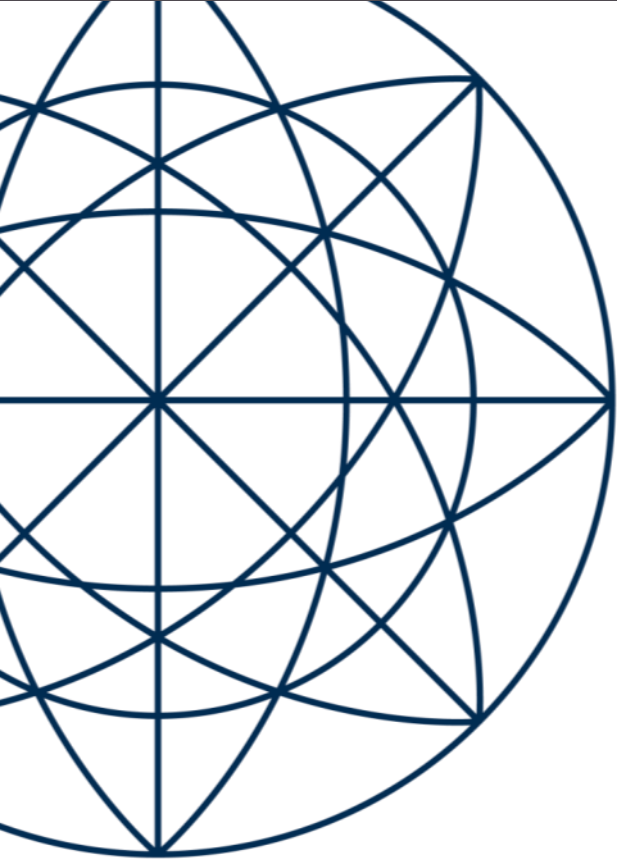

- > **EXPERTISE FOR SLITTING, REWINDING,
SURFACE QUALITY;**
- > **MARKED LEADER FOR HIGH-SPEED
SLITTING LINES**
- > **BEST PRACTISE FOR LOGISTIC;**
- >
- > **ONE SUPPLIER - ONE TAKE OVER POINT -
ONE PARTNERSHIP**

Danieli Fröhling
Innovation based on tradition
and know-how since 1947



**FRANK OTTERBACH
SALES MANAGER
DANIELI FRÖHLING**

**4TH IIAC IRAN INTERNATIONAL
ALUMINIUM CONFERENCE
OLYMPIC HOTEL
TEHRAN, IRAN
11-12 MAY 2016**

DANIELI FRÖHLING HIGH-SPEED SLITTING AND TRIMMING LINES TURNKEY FINISHING WORKSHOP SOLUTIONS

**DANIELI
PASSION TO INNOVATE
AND PERFORM
IN THE METALS INDUSTRY**

